

STRAIGHT PLUG SOLDER TYPE

R112.053.000

CABLE .085

Series : SMC

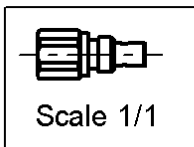
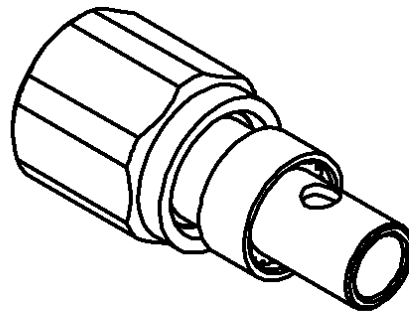
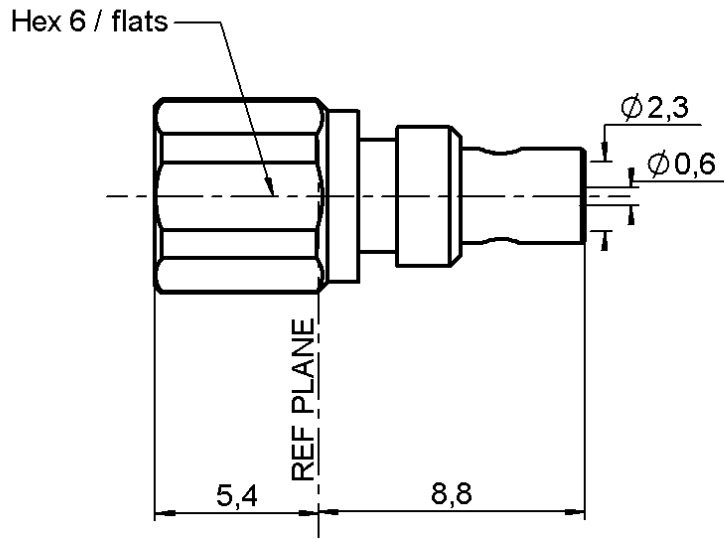

All dimensions are in mm.



COMPONENTS	MATERIALS	PLATINGS (µm)
BODY	BRASS	GOLD 0.2 OVER NICKEL 2
CENTER CONTACT	BERYLLIUM COPPER	GOLD 1.3 OVER NICKEL 2
OUTER CONTACT	-	-
INSULATOR	PTFE	-
GASKET	-	-
OTHERS PARTS	BRASS	GOLD 0.2 OVER NICKEL 2
-	-	-
-	-	-

Issue : 0040 N

In the effort to improve our products, we reserve the right to make changes judged to be necessary.



STRAIGHT PLUG SOLDER TYPE

R112.053.000

CABLE .085

Series : SMC

PACKAGING

Standard	Unit	Other
100	'W' option	Contact us

SPECIFICATION

CABLE ASSEMBLY

ELECTRICAL CHARACTERISTICS

Stripping	a	b	c	d	e	f
mm	3.00	1.00	0.00	0.00	0.00	0.00

Impedance		50	Ω
Frequency		0-10	GHz
VSWR	1.10 +	0.025	x F(GHz) Maxi
Insertion loss		0.125	\sqrt{F} (GHz) dB Maxi
RF leakage	- (62	- F(GHz)) dB mini
Voltage rating		250	Veff Maxi
Dielectric withstanding voltage		750	Veff mini
Insulation resistance		1000	M Ω mini

Assembly instruction :

Recommended cable(s)
RG 405
KS 1

Cable retention

- pull off **200** N mini
- torque **NA** N.cm

MECHANICAL CHARACTERISTICS

TOOLING

Center contact retention		
Axial force – Mating end	NA	N mini
Axial force – Opposite end	NA	N mini
Torque	NA	N.cm mini

Part Number	Description	Hexagon
.	.	.

Recommended torque		
Mating	30	N.cm
Panel nut	NA	N.cm
Clamp nut	NA	N.cm
A/F clamp nut	0.000	mm

Mating life	500	Cycles mini
Weight	3.000	g

OTHERS CHARACTERISTICS

ENVIRONMENTAL

Operating temperature	-65/+105	$^{\circ}$ C
Hermetic seal	NA	Atm.cm3/s
Panel leakage	NA	

Issue : 0040 N

In the effort to improve our products, we reserve the right to make changes judged to be necessary.



STRAIGHT PLUG SOLDER TYPE

R112.053.000

CABLE .085

Series : SMC

COMPONENTS

CENTER CONTACT

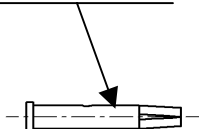

BODY

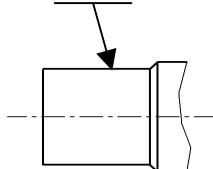

STRIPPING DIMENSIONS



1

- Strip off the outer conductor and the dielectric
- Solder the contact

NOTE : In order to ensure correct positioning of the contact it is recommended that a receptacle is fitted to the plug prior to soldering the body.

2

- Put the assembly into the body.
- Solder the body on the semi-rigid cable.

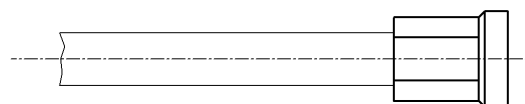
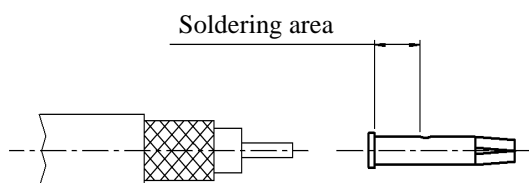

Issue : 0040 N

In the effort to improve our products, we reserve the right to make changes judged to be necessary.

